





EMS - 3D Scanning Hardware, Software and CAD Output Options

Z Corp Z Scanner Z800	Konica-Minolta Vivid 9i	Konica-Minolta Range 7	Surphaser 25HSX	Steinbichler – Comet 5
				
<p>The Z800 is hand held, very portable and easy to setup and use. The Z800 is great for tight locations and on-site scanning where other scanners can't access.</p>	<p>The Vivid 9i offers 3 lenses to scan at wide, medium and close range. Very good detail and accuracy for scanning small to large parts</p>	<p>The Range 7 offers very high accuracy and detail and is great for small to medium size parts where accuracy and detail is critical. The Range 7 is also a very good inspection tool.</p>	<p>The Surphaser is the first high accuracy, medium/long range 3D Scanner. It offers unmatched resolution and detail on large objects such as vehicles, aircraft, buildings, etc.</p>	<p>The Comet 5 is the highest accuracy and resolution 3D scanner on the market today. Great for very small detailed parts or inspection applications like turbine blades.</p>

EMS – 3D Scanning Software

GeoMagic	RapidForm	SensAble Technologies
		
<p>Great for STL editing and surface Creation</p>	<p>All the features of GeoMagic plus feature based solid modeling with direct interfaces to many of today's solid modeling CAD software</p>	<p>A virtual clay sculpting tool that allows the user to import scan data and sculpt it to any shape using a feedback haptic hand held device. Great for sculpture, fossils and artwork.</p>

EMS - 3D Scanning Deliverable CAD Data Formats

Sample Scan Part

This sample part is a cable connector housing about 2" x 2" x .5" in size. It was scanned with one of EMS's high resolution 3D scanners. Below is an outline of the different data formats that can be delivered.

Click the link below to download a zip file containing this sample model in the different formats described in this document.

[connector_housing.zip](#)



Polygon File

File Format: STL, PLY, OBJ, VRML

Description: A polygon file is a mesh file consisting of 3 sided triangles and a normal vector. Polygon files are the first step in the scanning process. The final polygon file will be "watertight" and the mesh optimized. Polygon files are good for "organic" free form shaped objects. They can be imported into animation, rendering and any software that can work with a polygon file. Many CAM software programs can generate a CNC cutterpath from a polygon file. Most mechanical CAD systems can NOT work with polygon files to make changes to the model.

Pros

- Lowest cost option
- Perfect for animation & simulation
- Many CAM programs can machine direct from STL
- Good for organic free form shape models like sculptures, artwork and archeological applications

Cons

- Not easy to work with in CAD software
- Files can be very large
- Making design changes can be difficult without special software (SensAble, 3D Max, Maya, etc)
- Sharp corners, planes, holes and other features may not be perfect

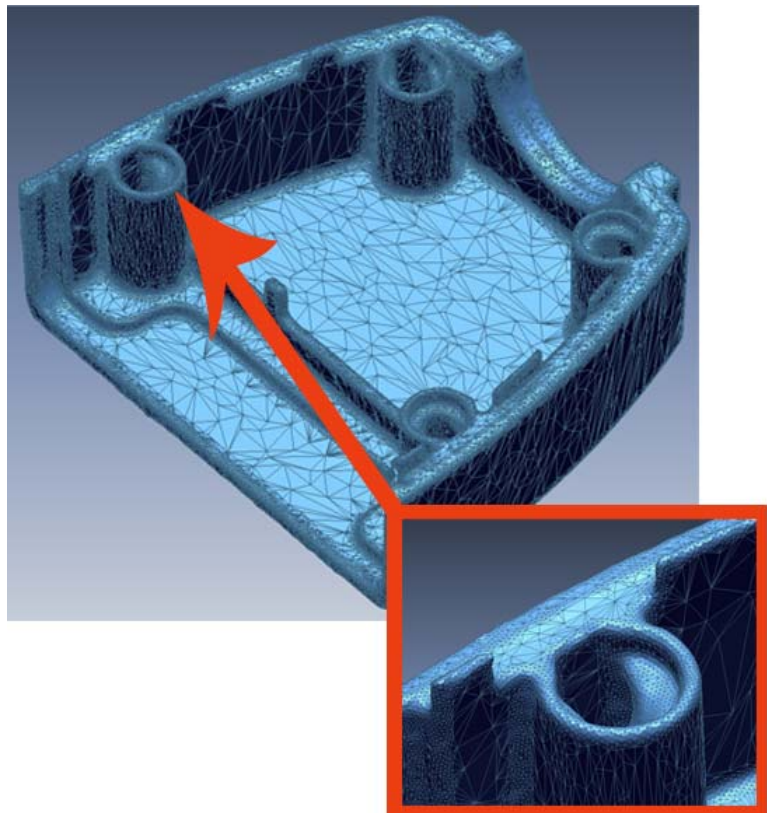

Surface Model

File Format: IGES, STEP

Description: A surface model is generated from a water tight polygon model. A surface model contains mathematical information that can be used in most CAD/CAM systems. This format is very useful for organic free form shape models such as boat hulls, automotive body panels, sculpture and more.

Pros

- Modest price
- Great for free form organic models
- All CAM software can use the data
- All CAD systems can import and work with a surface model but may have limits in editing the data

Cons

- Surface "patches" are random
- Limited editing capability in many CAD systems
- Sharp corners and holes may not be perfect

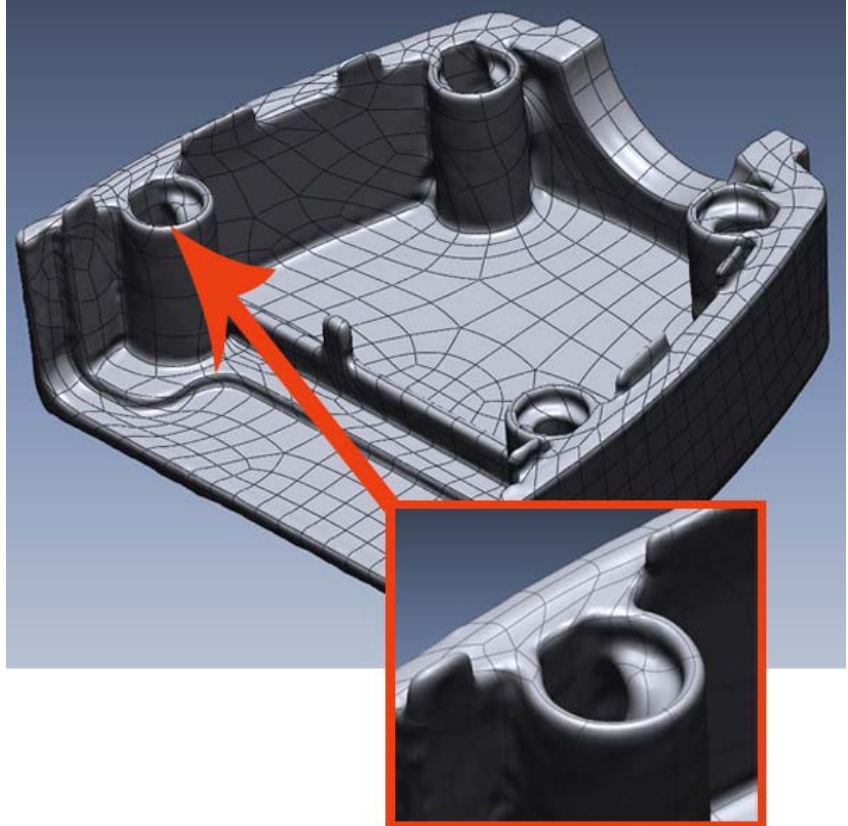

Feature Based Solid Model

File Format: IGES, STEP, Parasolid

Description: A feature based solid model is generated by recreating the model similar to most solid modeling CAD systems. The difference is the input information is the raw scan data. This process allows for the exact recreation of all features including sharp corners, holes and other features. The finished model can be compared to the raw scan data for accuracy.

Pros

- Best for "mechanical" type parts
- Accurate representation of part
- Model can be edited in most CAD systems

Cons

- More expensive option
- More time consuming to generate a finished model
- Not useful for organic free form models
- Some editing limitations in some CAD systems

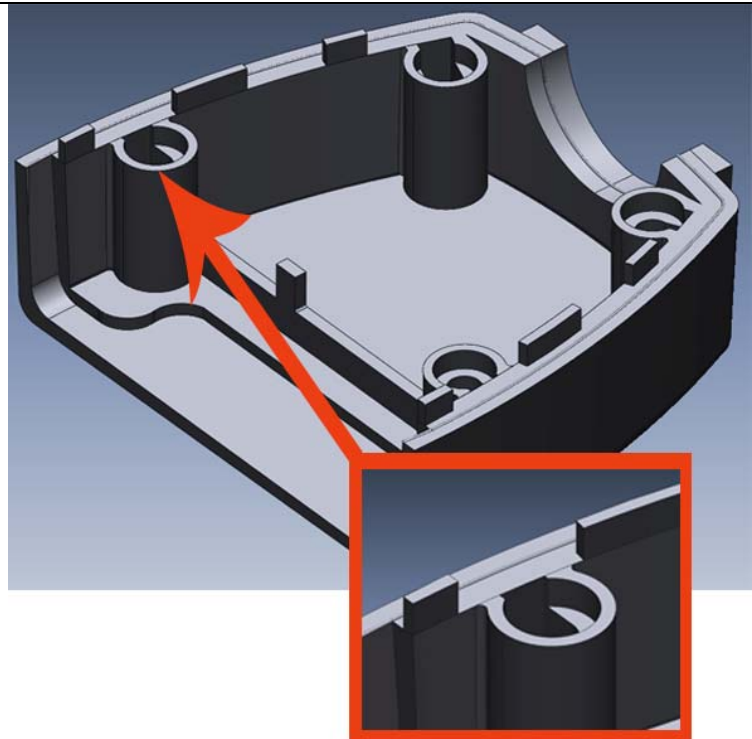

Parametric Feature Based Solid Models

File Format: SolidWorks, Pro/E Wildfire, Siemens NX

Description: A parametric feature based model includes additional information including dimensions, parametrics and the history tree. This is done by using a "live transfer" that recreates the model step by step in the native CAD system.

Pros

- Model is usually fully editable in the supported CAD systems

Cons

- Most time consuming to create
- Most expensive option

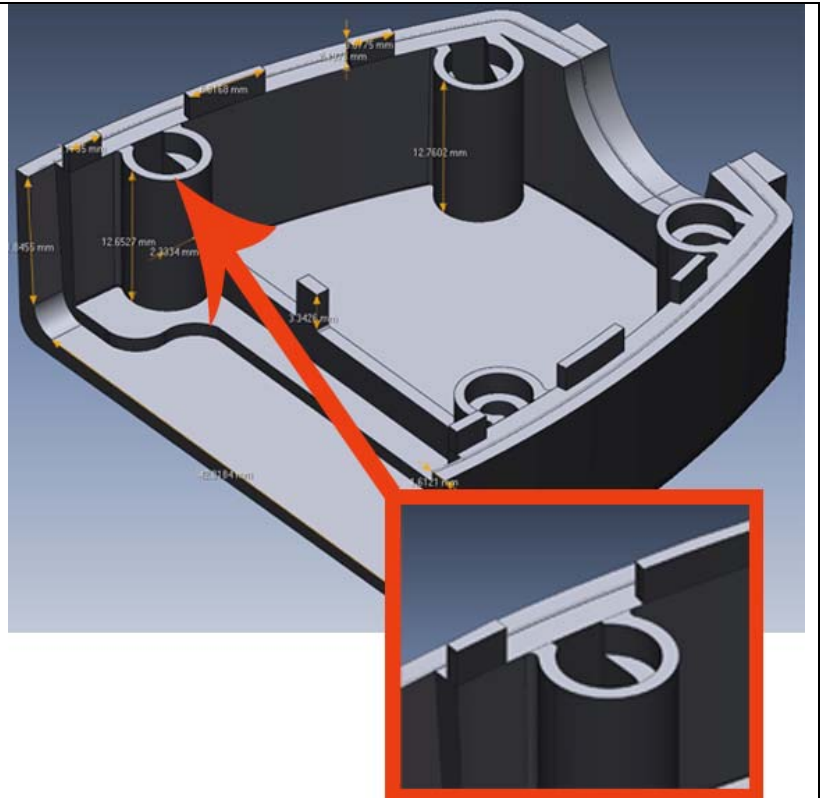

EMS has over 16 years in 3D scanning, product development and rapid prototyping. Contact EMS at **877-845-2700** to speak with an engineer who can answer any questions you may have about your needs.